



Durable Lightweight Tables & Chairs

RT Cart-Upright

S P E C I F I C A T I O N S

Position	Width	Height	Length	Weight
Upright	29.75" (76cm)	60" (152cm)	43.75" (111cm)	76" (34.5kg)
Tilted	29.75" (76cm)	62.5" (159cm)	64.5" (164cm)	76" (34.5kg)

Size	Header Clearance
RT3072	78" (198cm)
RT3096	98" (249cm)

Applications:

The RT Cart – Upright is designed to hold seven rectangular tables 72" to 96" long and five rectangular tables 48" to 60" long (these tables are wider). The cart will pass through standard doorways and elevators when holding tables up to 72" in length. The 10" wheels allow the cart to easily roll over a variety of floor surfaces. The back two swivel casters carry the load and steer the cart when it is fully leaned back. The inside surface of the cart is lined with industrial grade felt to protect the tables.

Primary Structure:

The cart shall consist of a frame, two swivel casters and two pneumatic wheels. The cart shall have an opening on one side, which allows the user to load and unload the tables. A 1 1/2" wide web strap is provided to secure the tables in place.

Castors:

The main wheels shall be 4" wide x 10" diameter, pneumatic, with ball bearings. They shall have a load capacity of not less than 325 pounds each.

The swivel casters shall be 1 1/4" wide x 5" diameter, non-marring, thermoplastic elastomer, with ball bearings. They shall have a load capacity of not less than 325 pounds each.

Primary Structure:

Part	Material Size
Main Frame	1 1/4" x 16 gauge (.065 wall) steel tubing
Frame Support Tubes	1" x 2" x 16 gauge (.065 wall) steel tubing
Caster Insert Tubes	1 1/4" x 14 gauge (.083 wall) steel tubing
Bottom Plate	10 gauge (.135) steel plate

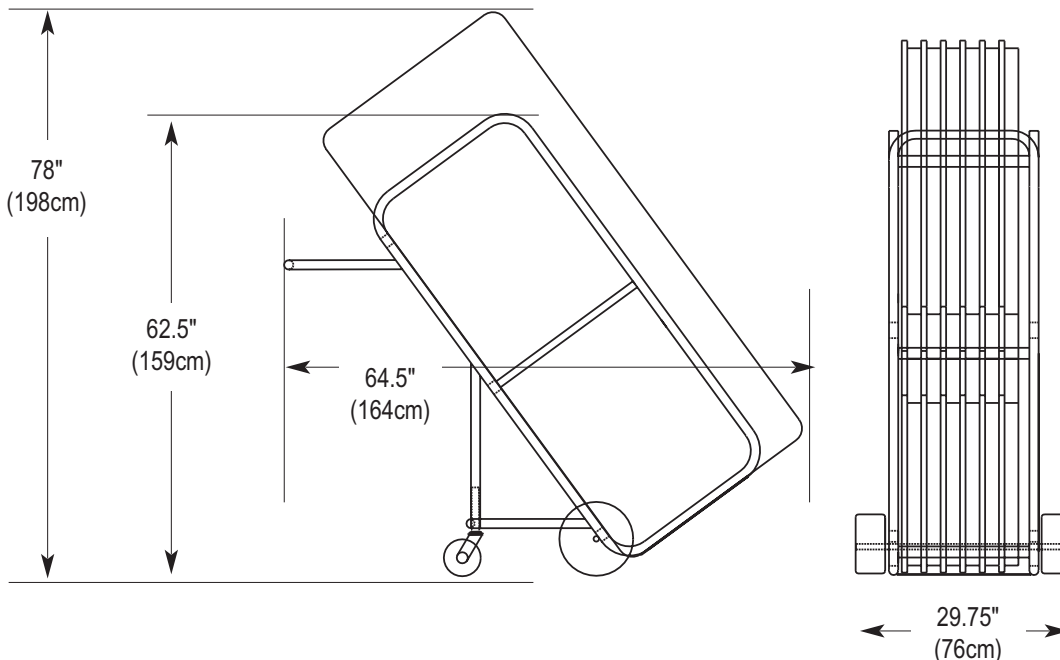

Part Number: CRTRTUBLK2