



Durable Lightweight Tables & Chairs

RT Cart-Stacking

SPECIFICATIONS

Cart	Width	Height	Length	Weight
RT3072	34" (86.4cm)	60" (152.4cm)	78" (198cm)	190 lbs (86.2kg)
RT3096	34" (86.4cm)	60" (152.4cm)	102.25" (259.7cm)	200 lbs (91kg)
RT3672	40" (104cm)	60" (152.4cm)	78" (198cm)	201 lbs (91kg)
RT3696	40" (104cm)	60" (152.4cm)	102.25" (259.7cm)	211 lbs (96kg)

Applications:

The RT Cart – Stacking is designed to hold up to 15 rectangular tables stacked flat ranging in size from 30"x 72" to 36" x 96". Carts will hold 30 rectangular tables sizes 18" x 72" and 18" x 96". The heavy duty construction allows the carts to be stacked up to 3 high only when the Mity-Lite X-Base – Stacking is used.

Primary Structure:

The main frame shall consist of 14 gauge (0.083") mild sheet metal bent to shape and welded to side runners consisting of 1 1/2" x 1 1/2" x 0.188" angle iron. Two cross pieces of 1 1/2" x 1 1/2" x 0.188" angle iron shall be welded to bottom of main cart to provide added support as well as a guide for the forks of the fork lift. Brackets to accommodate casters shall be welded to bottom of primary structure. Casters shall be attached to brackets using 3/8" x 5" carriage bolts with self-locking nuts.

End Frames:

End frames shall consist of uprights made of 1 1/2" x 1 1/2" x 7 gauge (0.188" wall) square tubing.

Bottom cross piece shall consist of 1 1/2" x 1 1/2" x 0.188" angle iron. A diagonal brace consisting of 1 1/2" x 0.25" flat steel bar shall be welded to the uprights and the bottom cross piece.

Top and bottom of end frame shall have a 1 1/4" x 1 1/4" x 0.125" angle iron welded to upright in a "v" orientation to accommodate stacking of carts. End frame shall have a middle cross welded in place 8" below the top to accommodate bolting the center bar between the end frames. End frame shall bolt to the main frame using 3/8" x 1" bolts with self-locking nuts. A diagonal brace consisting of 2" x 0.25" flat steel bar shall connect the end frames and main frame with 3/8" x 2 1/2" carriage bolts and self locking nuts.

Casters:

The cart shall have two swivel casters and two rigid casters. Wheels shall be 2" wide x 6" diameter, polyolefin, with 3/4" greasable roller bearings. Casters shall have a dynamic load capacity of not less than 850 pounds each.

RT3072

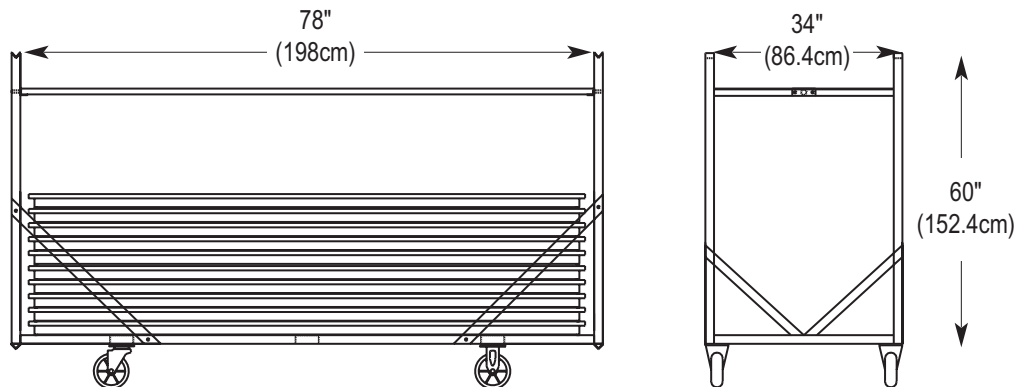

Part Number: CRTSKRT3072BLK