



Durable Lightweight Tables & Chairs

OT Cart-Large

SPECIFICATIONS

| Width | Height | Length | Weight |
|------------|---------------|--------------|--------------|
| 30" (76cm) | 44.5" (113cm) | 105" (267cm) | 96 lbs. (kg) |

| Size | Height (Loaded) | Length (Loaded) |
|---------|-----------------|-----------------|
| OT36120 | 124" (315cm) | 44.5" (113cm) |
| OT4296 | 105" (267cm) | 50.5" (128cm) |
| RT42102 | 112" (285cm) | 50.5" (128cm) |
| RT48120 | 124" (315cm) | 56.5" (128cm) |

Applications: The OT Cart – Large is designed to hold 10 tables stacked on edge. The side handles are provided to hold the tables up on edge. A front handle is provided to push or pull the cart. Industrial grade felt is provided on the bottom cross rails to protect the table's edge.

Castors: Wheels shall be 2" wide x 6" diameter soft, rounded tread, thermoplastic elastomer with roller bearings. Wheels shall be mounted on two swivel caster rigs and two fixed caster rigs. They shall have a load capacity of not less than 450 pounds each.

| Part | Material Size |
|------------|--|
| Main Frame | bent and punched 14 gauge (.083) steel sheet metal |
| Handles | 1" x 14 gauge (.083 wall) round tubing |

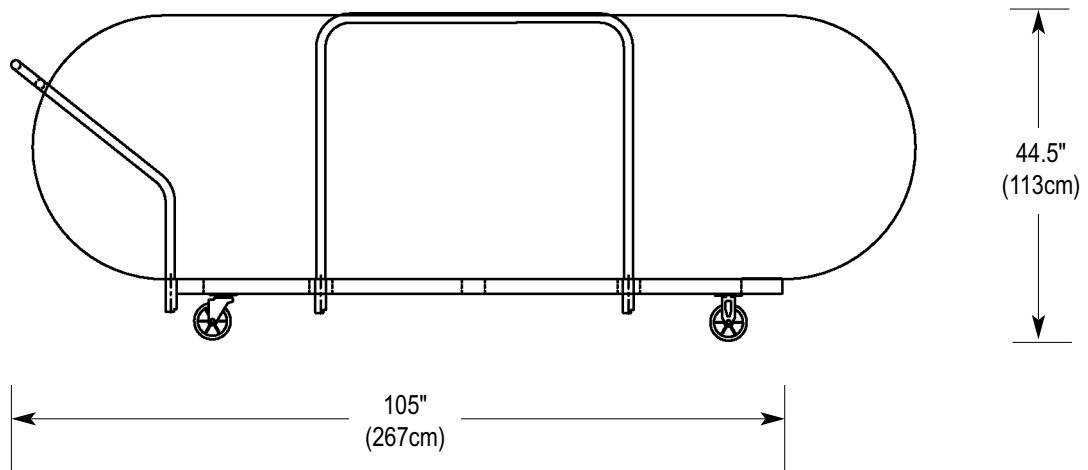

PART NUMBER: CRTOTLGBLK2