



Durable Lightweight Tables & Chairs

Mobile Buffet Table

SPECIFICATIONS

Base Size	Tier	Model Number
30"x72" [76cm x 183cm]	18"x72"	MB 3072 18 [46cm x 183cm]
30"x96" [76cm x 244cm]	18"x96"	MB 3096 18 [46cm x 244cm]
36"x72" [91cm x 183cm]	18"x72"	MB 3672 18 [46cm x 183cm]
36"x96" [91cm x 244cm]	18"x96"	MB 3696 18 [46cm x 244cm]
30"x72" [76cm x 183cm]		MB 3072 [76cm x 183cm]
30"x96" [76cm x 244cm]		MB 3096 [76cm x 244cm]
36"x72" [91cm x 183cm]		MB 3672 [91cm x 183cm]
36"x96" [91cm x 244cm]		MB 3696 [91cm x 244cm]

Outer Shell:

1. The top plastic shell, or tabletop surface, shall be formed from a nominal .060" [1.5mm] thick sheet of high impact ABS plastic. The entire top shell shall be permanently bonded to an internal wood laminate core (See "Internal Wood Laminate Core").
2. The table shell is normally supplied in beige with a fine "Haircell" texture.
3. The edge thickness of the table shall be a nominal 3/4" [19mm] and shall accept standard industry skirting clips.
4. The table top edge radius shall be nominally 3/16" [4.8mm]. The table bottom edge radius shall be approximately 5/64" [2mm].
5. The bottom plastic shell shall be formed from a nominal .050" [1.3mm] thick sheet of high impact, ABS plastic and shall be permanently bonded to the internal wood core where they come in contact.

Internal Wood Frame:

1. The inner wood frame shall be constructed of hardwood such as Alder or Whitewood, or wood laminates of equivalent strength and performance, and shall be nominally 3/4" [1.9mm] thick.
2. The frame shall consist of cross members at approximately 4 1/2" [59mm] intervals and a perimeter apron, minimum 2 1/4" [57mm] high.
3. Cross members shall be nominally 3 3/8" [85mm] and 1 3/8" [35mm] wide, with a minimum of four (4) of the wider cross members in each table.
4. Rectangular tables over six (6) feet [180cm] long shall have an additional cross member across the center, minimum 2 1/4" [57mm] high.
5. Tables shall have a "runner" on each side, minimum 2 1/4" [57mm] high.

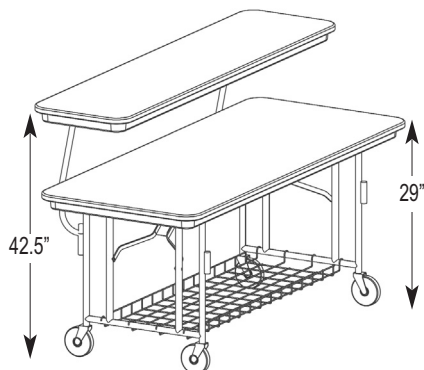

6. The framework shall be fastened together with 1 5/8" [41mm] hardened wood screws and 1 1/4" [32mm] pneumatically driven staples.

Internal Wood Laminate Core:

1. A 0.10"-0.14" [2.5mm - 3.6mm] thick wood laminate layer shall be permanently bonded to both outer shells of plastic where they come in contact with each other.

Internal Edge Reinforcing Extrusion:

1. An extrusion of high impact ABS shall be permanently bonded to the interior of the table, running continuously around the entire perimeter between corner components.

Corner Reinforcement Component:

1. All corners shall utilize an external corner-reinforcing component, which shall fit tightly between the ends of the wood perimeter members.

Trim/Bumper Extrusion:

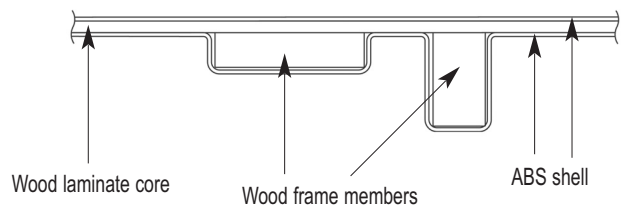

1. The trim extrusion shall be chemically welded to the entire perimeter of each table, welding the top shell to the bottom shell.
2. The trim extrusion shall provide an aesthetic, finished edge. It shall be nominally .080" [2mm] thick and 1/2" [12.5mm] wide.
3. The welding of the trim component shall be continuous, sealing the perimeter of the table and making it impervious to moisture.

Leg Construction:

1. The base table shall be equipped with fixed height reinforced B-type legs as standard, and shall have a 30" [76mm] height from top surface to floor. The tier 18" wide shall have insert-post-style legs and be 14" [36mm] from top surface of tier to top surface of base table.
2. The standard base table leg shall be constructed of 1" [25mm] diameter 16 gauge [1.5mm] steel tubing, vertical members shall each be welded to the horizontal tube and top bar.
3. The standard base table leg assembly shall incorporate a folding steel brace mechanism consisting of two (2) each .155" [4mm] z-bars and a 16 gauge (.060") minimum 2 x 3/4 [50.8mm x 19.1mm] U-channel 12" [304.8mm] long. The folding mechanism is connected together at 6 points using 1/4" [6.4mm] steel pivot pins. A gravity-operated 14-gauge [2.1mm] steel lock ring locks the mechanism.
4. Ends of legs shall be equipped with nylon or steel closures for floor protection.
5. Standard legs shall be cleaned and coated with brown mar-resist polyester powder, fused to the leg at 375°F [161°C] for 10 minutes.

Leg Mounting System:

1. Leg assemblies shall be mounted to the members of the internal wood frame using 16 gauge [1.6mm] minimum steel tube clamps.
2. The clamps are secured with a minimum of 2 each 1/4"[6.4mm] diameter x 3/4" long [6.4mm x 19.1mm] plated hex-head bolts into plated steel "T-Nut" type fasteners.
3. The folding braces shall be attached to the frame members with 16 gauge minimum steel brackets.
4. All brackets are secured with a minimum of 4 each 1/4" diameter x 3/4" long plated hex-head bolts into plated steel "T-Nut" type fasteners.
5. Each "T-Nut" type fastener shall be pressed into the frame members from the topside. The fasteners shall have at least three (3) anti-spin prongs each.

Casters:

1. Casters are 5" in diameter, non-marring, swivel and are equipped with brakes.

Performance Specifications:

1. The tabletop surface can withstand direct contact with hot objects having a temperature of no more than 160° F [71°C] for no more than 10 minutes.
2. Any rectangular table will support a static load of 2000 lbs. [907Kg, evenly distributed over the entire surface of the table. Under this load the legs shall experience no permanent bending or damage.
3. A 60" [152cm] round table, as an example, shall withstand a vertical drop onto a smooth hard surface, squarely on the table's edge from a height of 8.0" [20cm], at a table temperature of 72°F [22°C], with no substantial damage such as cracking or crushing.
4. All tables meet the American National Standard Institute's stability standard: ANSI-x5.5-1989.

Warranty:

1. Warranty shall be fifteen (15) years on all parts and labor.
2. A permanent label shall be affixed to the underside of the tabletop and shall state the manufacturer's name, address, phone number, standard warranty and exclusions.