



Durable Lightweight Tables & Chairs

CT Cart-Stacking

S P E C I F I C A T I O N S

Cart	Width	Height	Length	Weight
CT60	39" (99cm)	72" (183cm)	67.25" (171cm)	235 lbs (107kg)
CT72	40" (102cm)	83" (211cm)	78" (198cm)	255 lbs (116kg)

Applications:

The CT Cart – Stacking is designed to hold up to 10 circular tables set on edge ranging in diameter from 48" to 72". The heavy duty construction allows the carts to be stacked up to 3 high only when the Mity-Lite X-Base – Stacking is used.

Primary Structure:

The main frame shall consist of 10 gauge (0.135") mild sheet metal bent to shape and welded to side runners consisting of 1 1/2" x 1 1/2" x 0.1875 square tubing. Two cross pieces of 1 1/2" x 1 1/2" x 0.188" angle iron shall be welded to bottom of main cart to provide added support as well as a guide for the forks of the fork lift. Brackets to accommodate casters shall be welded to bottom of primary structure. Casters shall be attached to brackets using 3/8" x 5" carriage bolts with self-locking nuts.

End Frames:

End frames shall consist of uprights made of 1 1/2" x 1 1/2" x 11 gauge (0.120) square tubing. Bottom cross piece shall consist of 1 1/2" x 1 1/2" x 0.188" angle iron. Top and bot-

tom of end frame shall have a 1 1/4" x 1 1/4" x 0.125" angle iron welded to upright in a "v" orientation to accommodate stacking of carts. One end frame shall have a middle cross piece welded permanently in place and the other end shall consist of a loading ramp that can lock in the upright position. The ramp shall consist of a frame of 1" x 1" x 0.125" angle iron and 1/4" thick, hardwood face, paint lock plywood bolted in place using 0.25" x 1.25" carriage bolts and self-locking nuts. A diagonal brace consisting of 2" x 0.25" flat steel bar shall connect the end frames and main frame with 3/8" x 2-1/2" carriage bolts and self-locking nuts.

Castors:

The cart shall have two swivel casters and two rigid casters. Wheels shall be 2" wide x 6" diameter, polyolefin, with 3/4" greasable roller bearings. Casters shall have a dynamic load capacity of not less than 850 pounds each.

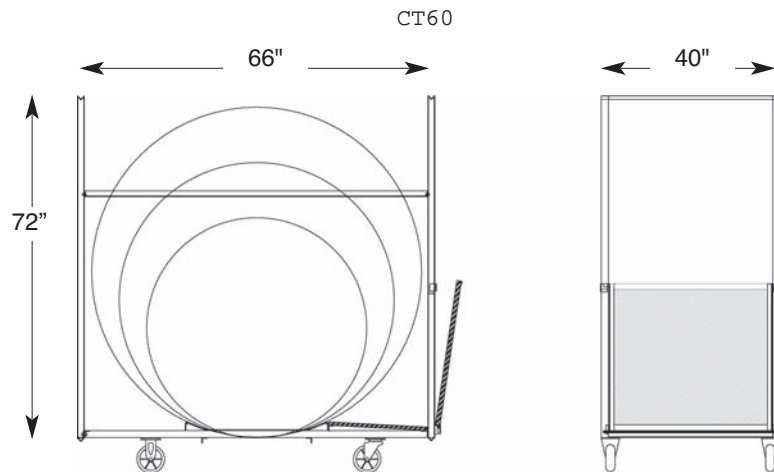

Part Number: CRTSKCT60BLK